

Catheter-Based Systems With Integrated Stretchable Sensors and Conductors in Cardiac Electrophysiology

We present novel mechanics, materials and integration strategies for this new class of bioelectronics onboard minimally invasive catheter based systems. Representative examples highlight the clinical significance soft biointegrated electronics.

By STEPHEN P. LEE, LAUREN E. KLINKER, LEON PTASZEK, JOHN WORK, CLIFF LIU, FERNANDO QUIVARA, CHAD WEBB, CANAN DAGDEVIREN, JOHN A. WRIGHT, JEREMY N. RUSKIN, MARVIN SLEPIAN, YONGGANG HUANG, MOUSSA MANSOUR, JOHN A. ROGERS, AND ROOZBEH GHAFFARI

ABSTRACT | Established classes of high-performance electronics have driven advances in interventional biomedicine. However, the large size, planar geometry and stiff mechanical properties of standard conventional electronics employed in medical devices give rise to important integration challenges with soft biological tissue. Stretchable and flexible biointegrated electronics could improve treatment procedures across a broad range of applications, including cardiac, neural and endovascular therapies. Here we present novel mechanics, materials and integration strategies for this new class of bioelectronics onboard minimally invasive catheter based systems. Co-located arrays of sensors and actuators affixed to cardiac and angioplasty balloon catheters capture new sensory information during ablation procedures, offering physicians the abi-

lity to adjust placement and treatment intra-procedurally. New circuit topologies, enabled by stretchable electronics, also overcome long standing challenges associated with transmitting vast amounts of data through narrow catheter lumens, thus allowing for a large number of sensors to be multiplexed for mapping electrophysiological activity with high spatiotemporal resolution and with a minimal number of routing wires. We present representative examples that highlight the clinical significance of soft bio-integrated electronics, along with the mechanics and processes that enable this technology.

KEYWORDS | Flexible electronics; biosensors; semiconductors; microfabrication; electrophysiology; vasculature; biomedical devices

Bio-integrated electronics that interface with cellular and sub-cellular constituents of soft living tissues can fundamentally change the way medical devices diagnose and deliver therapy [1]–[5]. Existing cardiac assist and deep-brain stimulation devices, which contain packaged electronic parts, have already improved the quality of life for patients with abnormal heart rhythm disorders, treatment-resistant depression, and Parkinson’s disease, but all of these existing solutions contain arrays of passive metal electrodes and wires that target large clusters of cells and nerve fibers indiscriminately with limited spatial precision. These recording and stimulation electrodes are

Manuscript received September 10, 2014; revised January 5, 2015; accepted January 26, 2015. Date of current version May 19, 2015.

S. P. Lee, L. E. Klinker, J. Work, C. Liu, F. Quivara, J. A. Wright, and R. Ghaffari are with MC10 Inc., Cambridge, MA 02140 USA (e-mail: rghaffari@mc10inc.com).

L. Ptaszek, J. N. Ruskin, and M. Mansour are with the Cardiac Arrhythmia Unit, Massachusetts General Hospital, Boston, MA 02140 USA.

C. Webb, C. Dagdeviren, and J. A. Rogers are with the Department of Materials Science and Engineering, University of Illinois at Urbana-Champaign, Urbana, IL 61801 USA.

M. Slepian is with the Departments of Medicine and Biomedical Engineering, Sarver Heart Center, University of Arizona, Tucson, AZ 85724 USA.

Y. Huang is with the Department of Civil and Environmental Engineering, Northwestern University, Evanston, IL 60208 USA.

Digital Object Identifier: 10.1109/JPROC.2015.2401596

0018-9219 © 2015 IEEE. Personal use is permitted, but republication/redistribution requires IEEE permission. See http://www.ieee.org/publications_standards/publications/rights/index.html for more information.

prevalent in many existing catheter-based solutions and represent the gold standard of care in interventional medicine [2]–[4]. However, these devices are largely restricted to interactions with biological structures at scales that are orders of magnitude larger and stiffer than individual living cells. A powerful alternative would be to dramatically reduce the size and mechanical hardness of devices and sensors that directly interface with soft tissue and organs [1], [3]. Soft, stretchable integrated circuits, sensors and actuators that achieve intimate contact with target cells at a high level of specificity constitute a viable solution for emerging medical systems.

This new class of electronics has significant implications for growing populations of patients stricken with hypertension, heart disease [6], and neurological disorders. Global forecasts predict a rapid rise in the number of patients with strokes, complex arrhythmias, as well as neurological disorders, like epilepsy and Alzheimer's [7], [8]. Highly localized methods of detection and therapy (e.g., electromodulation of neural signaling and ablation) are becoming attractive treatment strategies in these patient populations. The ability to instrument mechanical devices (i.e., catheters) with arrayed forms of sensors and actuators that exploit flexible and stretchable circuits offers opportunities to improve efficacy and to reduce procedure time and cost.

In this report, we highlight recent developments in soft, stretchable bio-integrated medical systems and demonstrate catheter-based systems integrated with sensors that exploit unusual mechanics and designs using existing manufacturing processes. We provide recent examples of catheter-based systems that have been applied across several disciplines including cardiac, neural, and endovascular procedures. By leveraging heterogeneous collections of sensors and actuators, these catheter-based systems highlight the opportunity to address highly localized target sites to detect and/or modulate the body's natural signaling circuits.

I. MATERIALS, MECHANICS, AND MICROFABRICATION PROCESSES

Development of ultrathin, stretchable arrays of sensors and actuators for catheter-based systems begins with conventional microfabrication and photolithography techniques, as described previously [1], [3]. Ultrathin metal layers and single-crystal inorganic nanomaterials released from donor wafers are integrated with polymeric and elastomeric balloon substrates using interfacial adhesives, plasma treatment, and transfer printing strategies [1]–[3]. Transfer printing onto a three-dimensional balloon begins with a soft, rubber-like stamp material called (poly)dimethylsiloxane (PDMS) that retrieves biosensor arrays and nanomaterials via van der Waals forces. This transfer process can be performed over large areas of segmented arrays of sensors using a flat stamp or over selected areas using a structured

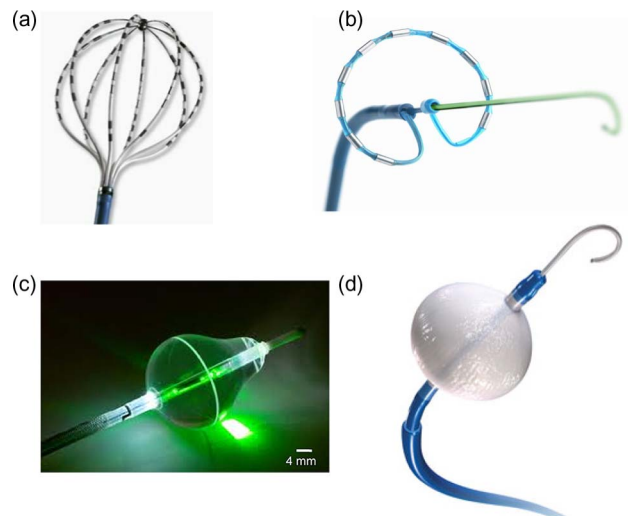

Fig. 1. Multielectrode and balloon-based catheters used for ablating and mapping electrical activity of cardiac tissue [3]. (a) Multielectrode basket catheter (ConstellationTM, Boston Scientific; Boston, MA, USA) provides high-density mapping of electrical activity within the atria. (b) Multielectrode mapping and ablation catheter (MAACTM, Medtronic; Minneapolis, MN, USA). (c) HeartLight laser-based ablation balloon catheter (Cardiofocus Inc.; Marlborough, MA, USA). (d) Cryoballoon ablation catheter (Medtronic; Minneapolis, MN, USA).

stamp. In the next step, the picked biosensors and circuitry are selectively placed on the complex three-dimensional geometry of a balloon catheter while it is in its inflated state. Thin glue layers, such as polyimide or epoxies, and plasma treatment promote high adhesion strength and ruggedness, enabling multiple inflation and deflation cycles during use. Once arrays of sensors are affixed to the balloon surface, anisotropic conductive films are used to connect sensor leads to copper wires, which electrically route signals to an external data acquisition console.

These ultrathin designs achieve flexibility over very small bending radii (< 1 mm). However, extreme bending and stretching conditions could induce significantly greater strains or fractures, particularly in instances where these electronics must interface with soft tissues of the heart. For example, electronics inside the chambers of the heart may undergo large strains up to 20%–30%. Sensors and electrodes on balloon catheters for minimally invasive procedures thus require even higher stretchability [1]. To alleviate the strains induced in these use-cases, serpentine layouts of polymers, metals and nanomaterials are required [1]–[3].

II. INSTRUMENTED CARDIAC ABLATION CATHETERS

Atrial fibrillation (AF) affects more than five million patients in the developed world and is the leading cause of stroke in cardiac patients [10], [11]. With up to 400 000

new cases diagnosed yearly [7], the adverse outcomes of AF range from congestive heart failures to sudden death. Pulmonary vein (PV) isolation with radio-frequency (RF) energy ablation catheters has become a primary intervention for complex arrhythmias [12], [13] and represents a procedure that could benefit from localized sensing and therapy. RF ablation involves delivery of energy in a point-by-point manual fashion to specific locations within left atrium, such as where the PVs intersect the atrial wall. Positioning mapping and/or ablation catheters containing point electrodes [Fig. 1(a) and (b)] requires significant time and dexterity, often leading to inconsistent outcomes across multiple patients [13] and increasing the risk of stroke and other clinical complications.

Emerging balloon catheter-based systems under-development and in clinical trials rely [Fig. 1(c) and (d)] solely on balloon substrates to conform to the anatomical structure of the heart [14]–[16]. These balloons inflate within the left atrium and create continuous rings of conformal contact between the balloon and the tissue followed by delivery of cryo- or laser-based ablation therapies. RF and cryoablation energy destroy the targeted cells, thereby

correcting the aberrant electrical circuits that underlie arrhythmias. Although conceptually straightforward, such balloon ablation catheters fail to provide information on the electrical state of intracardiac surfaces or sensory feedback about mechanical contact or temperature profile of the target tissue [1]–[3]. The “instrumented” balloon catheters with integrated conductors and active sensors that allow multisensory feedback, pacing, and ablation functionality could thus offer a significant advance over existing balloon-based and multielectrode catheter devices.

Cardiac ablation serves as a compelling case study to evaluate the benefits of soft biointegrated systems. In particular, the co-location of sensors with ablation electrodes provides real-time intra-procedural feedback on the efficacy of ablations without the use of additional catheters. Flexible and stretchable sensor and actuator subcomponents must be mechanically robust to match the dynamical inflation and deflation cycles of balloon catheters. Ultra-thin electronics, fabricated using flex processes and unpackaged embedded die processes, can be made to stretch as a network by using unique spring-like geometrical layouts [Fig. 2(a)–(c)]. Thin film deposition, etching, and

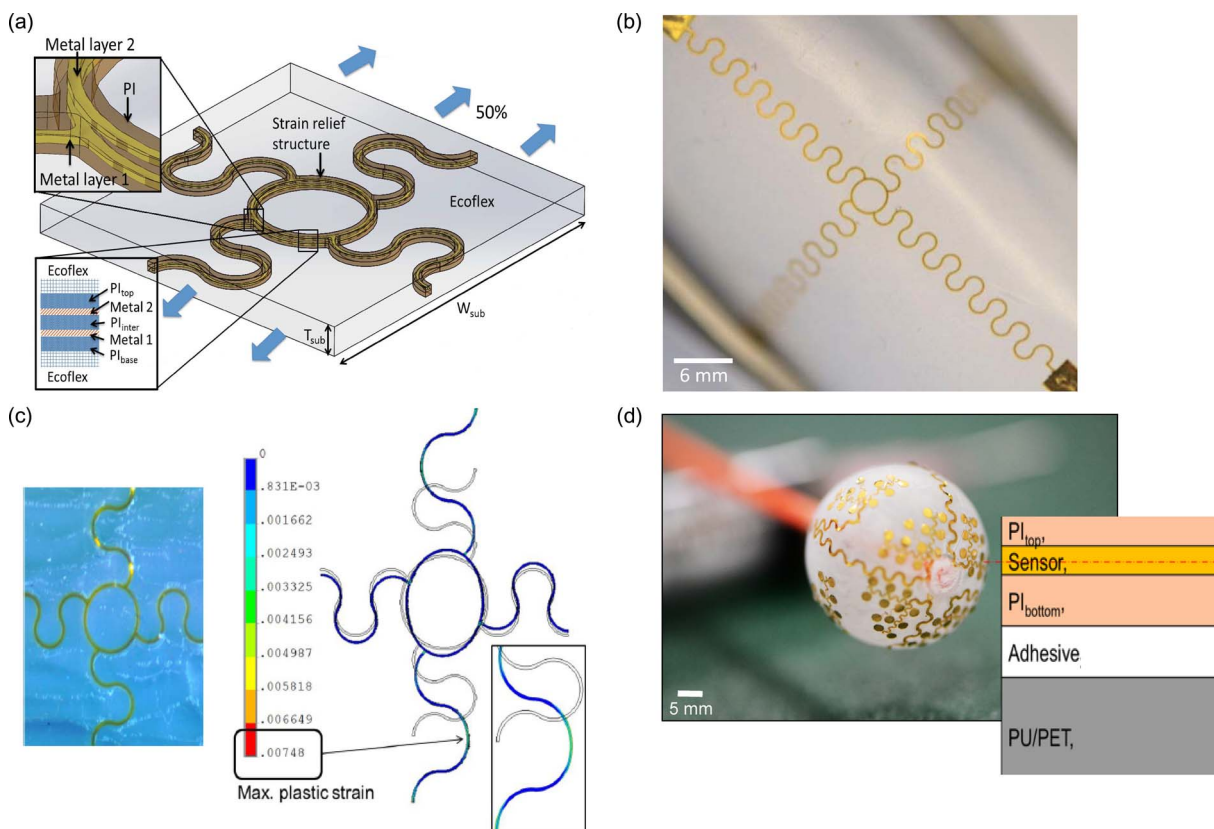

Fig. 2. Multilayered stretchable interconnects. (a) Illustration of interconnect structures with meandering metal interconnects used to accommodate strain in highly stretchable electronics (26). (b) Image strain relief structure encapsulated in elastomer. (c) Image of interconnect structure experiencing ~50% strain. Model simulation showing plastic strain distribution in response to 50% strain (26). (d) Representative balloon catheter that employs a network of electrodes connected mechanically and electrically via spring-like meandering interconnects. The PI and sensor layers in the stack interface with biological tissue, whereas the PU/PET layer constitutes the inner layer of balloon material.

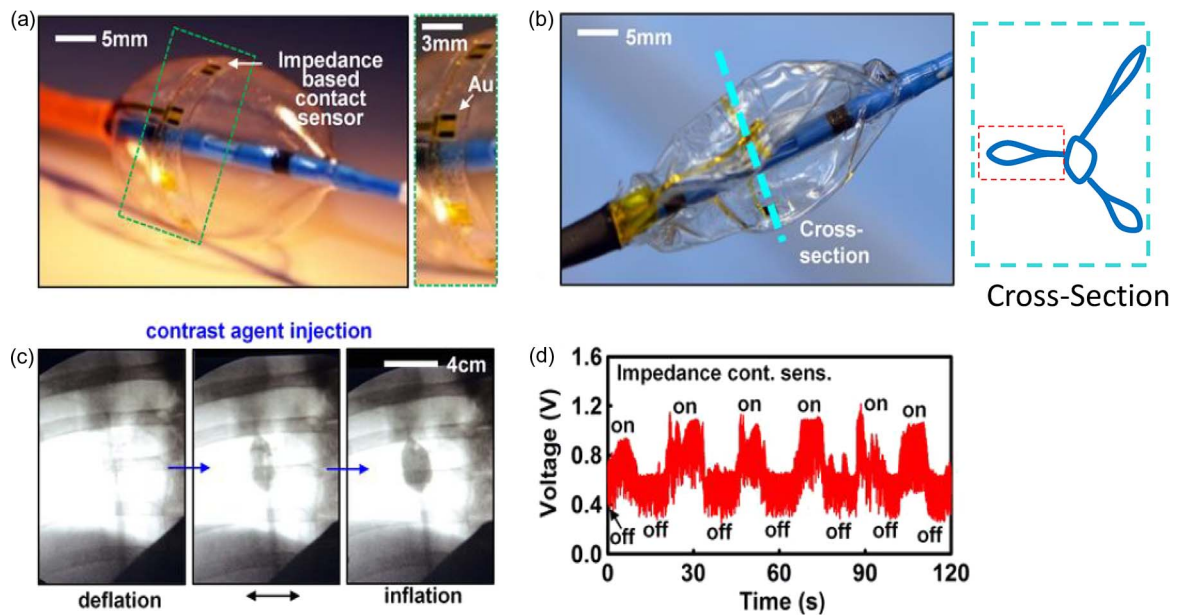

Fig. 3. Impedance-based contact sensor balloon catheters [17]. (a) Optical image of a device (Left), with magnified view (Right). (b) Picture of balloon in its deflated state with schematic of the cross-section. (c) X-ray image of balloon catheter demonstrating contact and noncontact conditions near the superior vena cava (SVC) in live porcine model. (d) In vivo measurements of impedance during contact with the ostium of the superior vena cava [18].

photolithographic patterning strategies are used to lay stacks of polyimide, adhesives, silicon-based semiconductors, and metal layers, which allows for significant reduction in bending stiffness and enhanced flexibility due to minimized stack thickness. The mechanical layouts of these systems are driven by theoretical analysis with parameters tuned for reversible elastic response to large-strain deformation [Fig. 2(c)] [17]. Strain concentration is limited in the neutral mechanical plane, where sensors and actuators are located, and constrained to the interconnected regions alleviating stress from the sensitive elements and providing further mechanical support. These mechanical properties are well suited for three-dimensional balloon structures, which undergo considerable stretching and bending during inflation/deflation cycles [Fig. 2(d)].

Kim *et al.* demonstrated stretchable impedance-based contact sensors [Fig. 3(a)–(c)], temperature and pressure sensors on balloon catheters to assess adequate contact with the tissue [18]. The temperature sensors consist of thin resistive films of titanium-platinum (5 nm/50 nm thick). Here, the thin layers of Ti/Pt are deposited by electron beam evaporation and patterned by photolithography and then lift-off creates intricate micro-patterns of sensors. The Ti/Pt layer is strategically deposited on a flexible but nonstretchable island of polyimide, which helps reduce the effects of strain on the temperature measurement during inflation and deflation [18]. Surface treatment of the PI with UV/Ozone or deposition of a thin silicon dioxide (SiO_2) layer (~ 50 nm) on top of PI improves the adhesion of the Ti/Pt. These temperature sensors are located near the

ablation electrodes decorated on the balloon surface to provide an accurate assessment of tissue temperatures during ablations. Calibration measurements conducted under extremely low (e.g., cryoablation) and elevated (e.g., RF energy delivery) temperature conditions yielded a monotonic relation between impedance and measured temperature, with a slope of $\sim 1.91 \Omega/^\circ\text{C}$ [18]. In the case of irrigated RF ablation catheters and cryoballoons, this sensitivity is sufficient to provide precise feedback on thermal properties at the tissue-balloon interface.

Similarly, impedance-based contact sensors are fabricated on polyimide islands tied together by serpentine interconnects. Lithographic processing and vertical trench dry-etching techniques yielded isolated contact sensors ($\sim 1 \text{ mm}^2$, and $\sim 12 \mu\text{m}$ total thickness of stack) that remain tethered to the underlying silicon or glass wafer through “anchor” structures. This process can be used to yield electrodes for mechanical contact sensing and electrogram measurements. Each contact sensor consists of a bipolar pair of electrodes that measure a change in impedance generated by an excitation current. For the experiment, the excitation current was set to 10 μA and measurements were taken at ~ 1 kHz. An array of bipolar electrodes thus can be used to evaluate contact according to changes in impedance, which can increase by up to a factor of ~ 1.5 – 2 .

The individual sensors reside equatorially around the balloon and are used to detect mechanical contact with cardiac tissue to aid in catheter positioning and to confirm contact during ablation events. These impedance-based sensors can also be used to assess the contact pressure at

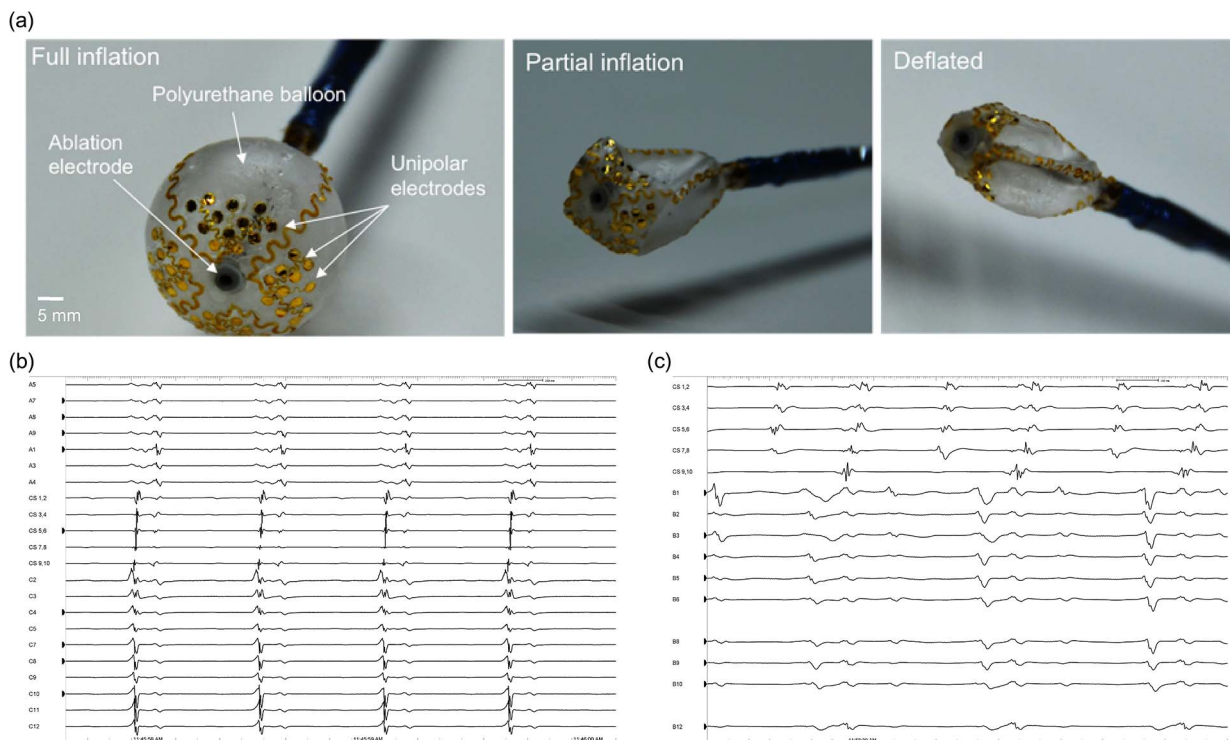

Fig. 4. Array of 64 electrodes on balloon catheter. (a) Images of instrumented balloon in its inflated (left), partially inflated (middle) and deflated (right) states. (b) Electrograms for normal sinus rhythm captured with balloon electrodes deployed in the right atrium of a swine. (c) Electrograms of induced tachycardia showing disorganized rhythm captured using balloon electrodes in the right atrium.

the balloon-tissue interface. An array of contact sensors provides feedback to physicians with significantly higher accuracy than existing x-ray based imaging techniques [Fig. 3(d) and (e)].

III. HIGH SPATIAL RESOLUTION MAPPING CATHETERS WITH FLEXIBLE/STRETCHABLE ACTIVE ELECTRODES

In more advanced arrhythmia cases, such as persistent AF, the mechanisms underlying depolarization and hyperpolarization wave fronts remain poorly understood, and ablation targets are not well defined [19], [20]. As a result, this form of AF is significantly more challenging to treat compared to paroxysmal AF. Current ablation targets in persistent AF include areas exhibiting complex fractionated atrial electrograms (CFAEs). CFAEs are electrical recordings with a highly disorganized appearance, which may represent rapid electrical activity from a nearby driving force (rotor) [21], [22]. While these areas exhibit CFAE appearance, they do not play a major role in maintaining AF. However, due to the lack of high density mapping capabilities in the clinical setting, the distinction between drivers of AF and passive CFAEs is not currently possible, leading to erroneous ablation in a large number of patients.

Although basket catheters have a greater number of electrodes compared to point ablation catheters, they

still lack the resolution necessary to map persistent AF. The spatial density of electrodes is on the order of 0.1 electrode/cm², whereas the action potential wave fronts disperse at much finer resolution. By applying micro-fabrication and photolithographic techniques, instrumented balloon-based catheters with electrode spatial densities of 15 electrodes/cm² are now possible [Fig. 4(a)], enabling high spatial resolution mapping of the atrial walls [18].

While conventional basket catheters cover the entire left atrial surface area, they lack resolution to match this spatial resolution during *in vivo* recordings [Fig. 4(b), (c)]. As a result, current mapping solutions rely on interpolation algorithms and other postprocessing techniques to accommodate their limited resolution. However, increasing the spatial density of electrodes in a scalable way requires multiplexing in order to minimize the number of sensor wires that extend through the catheter lumen. Multiplexing sensor data offers a potential solution; however, in practice, using commercially available multiplexer ICs and integrating them in the shaft has been challenging, largely because commercial off the shelf multiplexers have form factors that are not amenable to routing through a small diameter catheter; many have widths that exceed the diameter of a catheter. Moreover, there are numerous electrode wires that must be routed to the multiplexer, to reduce crowding in the catheter shaft.

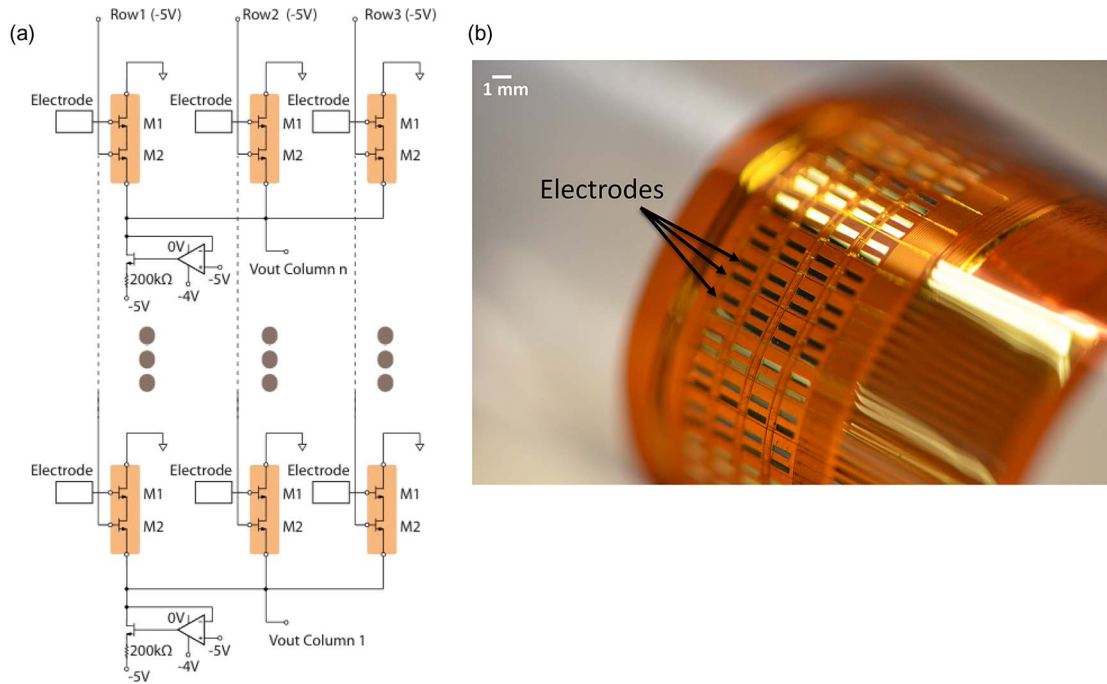

Fig. 5. Distributed multiplexing. (a) An example of row/column selection using source-followers in a distributed multiplexing arrangement. (b) Buffered, multiplexed electrodes on a polyimide sheet.

The ability to integrate silicon-based electronics on extremely elastic substrates introduces ways to integrate sensing, actuation, amplification, logic, and switching capabilities onboard cardiac balloon catheters. The underlying sensing technology has been previously developed onboard catheters that employ these thin, conformal arrays

of sensory electronics embedded in deformable surfaces (i.e., silicone or polyurethane balloon skins) [1], [5]. A compelling solution is to develop distributed multiplexing as shown in the circuit diagram in Fig. 5. Source followers, M1, buffers the signal, a CMOS switch, M2, opens or closes each active electrode’s output to effectively multiplex its

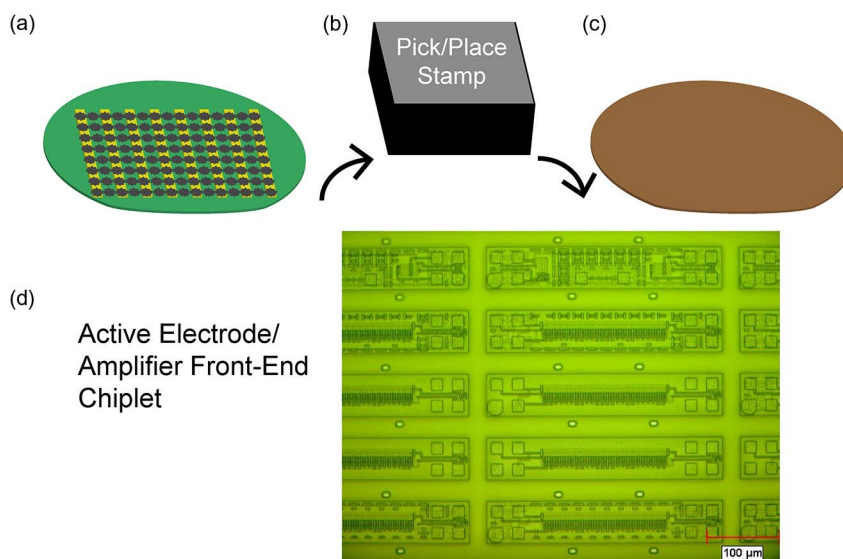

Fig. 6. Fabricated devices using a commercial SOI process. (a) The “donor” wafer undergoes a modified commercial fabrication process. (b) and (c) After under-etch, devices are picked and transferred to an “acceptor” wafer. (d) Magnified image of transferred chiplets on acceptor wafer. Interconnect traces are deposited following this CMOS processing stage.

respective amplifier/electrode creating a distributed multiplexer on the surface of a sheet or balloon catheter [Fig. 5(a)]. In this example, each electrode is addressed via row/column select. Sixty-four electrodes thus contain 16 row column select lines yielding a savings in input/output [Fig. 5(b)].

Fabrication of distributed multiplexers is an enhancement of previous work by Kim *et al.* [23], achieved by the following process steps: the amplifier multiplexer circuit is fabricated using a silicon-on-oxide foundry CMOS process [Fig. 6(a)]. Each electrode amplifier/multiplexer pair is fabricated within a trench and anchored to the trench walls by tethers. The trench is vertically, wet etched away, leaving the amplifier/multiplexer floating above the trench, held in place by the anchors. An elastomeric stamp head affixed to a modified pick and place machine [Fig. 6(b)] performs the microtransfer printing by peeling the amplifier/multiplexer (5 μm thick) off the silicon “donor” wafer and transferring it to a polyimide substrate (1 μm thick) on an “acceptor” wafer. Deposited metal traces connect the array of amplifier/multiplier “chipllets” after micro-transfer [Fig. 6(c) and (d)]. Serpentine and active devices are then encapsulated with a polymer layer (e.g.,

polyurethane). The overall structure can accommodate radii of curvature of less than 1 mm based on analysis and verified through experiment. The polyimide substrate containing the array can be affixed to a balloon catheter or can be used in sheet form [1], [5], [17], [18].

IV. CONCLUSION

Soft, stretchable biointegrated electronics have direct implications on the development of emerging balloon-based catheter systems in cardiac electrophysiology. Integration of sensors, actuators, amplification circuitry and multiplexing could significantly reduce the size of catheter lumens to reach additional biological locations while dramatically enhancing sensing and signal to noise quality. In addition to instrumented endovascular catheters, soft bioelectronics can be applied to other substrates, including biofilms (e.g., silk fibroin) that can conform to unique tissue geometries, such as the sulci and gyri of the brain, and sutures instrumented with onboard flexible sensor electronics [24]. These examples highlight the vast set of applications of stretchable, bio-integrated electronics to enhance cardiac, neural, and endovascular procedures. ■

REFERENCES

- [1] D. H. Kim *et al.*, “Multifunctional stretchable devices on compliant balloon catheters for in-vivo electrophysiological mapping and ablation therapy,” *Nature Mater.*, vol. 10, no. 4, pp. 316–323, 2011, PMID: 21378969.
- [2] M. Slepian, R. Ghaffari, and J. A. Rogers, “Multifunctional balloon catheters of the future,” *Intervent. Cardiol.*, vol. 3, no. 4, pp. 417–419, 2011.
- [3] D. H. Kim, R. Ghaffari, N. Lu, and J. A. Rogers, “Flexible and stretchable electronics for biointegrated devices,” *Annu. Rev. Biomed. Eng.*, vol. 14, pp. 113–1128, 2012.
- [4] C. Famm, B. Litt, K. J. Tracey, E. Boyden, and M. Slaoui, “Drug discovery: A jumpstart for electrochemicals,” *Nature*, vol. 496, pp. 159–161, 2013.
- [5] J. Viventi *et al.*, “A conformal, bio-interfaced class of silicon electronics for mapping cardiac electrophysiology,” *Sci. Translat. Med.*, vol. 2, no. 24, 2010, doi:10.1126/scitranslmed.300073824ra22.
- [6] World Health Organization Statistics, 2012.
- [7] A. S. Go *et al.*, (2001). Prevalence of diagnosed atrial fibrillation in adults: National implications for rhythm management and stroke prevention: The AnTicoagulation and Risk Factors in Atrial Fibrillation (ATRIA) Study. *J. Amer. Med. Assoc.* [Online]. 285(18), pp. 2370–2375. Available: <http://www.ncbi.nlm.nih.gov/pubmed/11343485>
- [8] R. Brookmeyer, E. Johnson, K. Zeigler-Graham, and H. M. Arrighi, “Forecasting the global burden of Alzheimer’s disease,” *Alzheimer’s Dementia*, vol. 3, pp. 186–191, 2007.
- [9] H. M. De Boer, M. M. Mula, and J. W. Sander, “The global burden and stigma of epilepsy,” *Epilepsy Behav.*, vol. 12, pp. 540–546, 2008.
- [10] M. D. Ezekowitz and J. A. Levine, “Preventing stroke in patients with atrial fibrillation,” *J. Amer. Med. Assoc.*, vol. 281, no. 19, pp. 1830–1835, 1999.
- [11] V. Fuster *et al.*, “ACC/AHA/ESC 2006 Guidelines for the Management of Patients with Atrial Fibrillation: A report of the American College of Cardiology/American Heart Association Task Force on Practice Guidelines and the European Society of Cardiology Committee for Practice,” *Circulation*, vol. 114, no. 7, pp. e257–e354, 2006, doi:10.1161/CIRCULATIONAHA.106.177292.
- [12] M. Haissaguerre *et al.*, “Catheter ablation of long-lasting persistent atrial fibrillation: Clinical outcome and mechanisms of subsequent arrhythmias,” *J. Cardiovasc. Electrophysiol.*, vol. 16, no. 11, pp. 1138–1147, 2005, doi:10.1111/j.1540-8167.2005.00308.x.
- [13] H. Calkins *et al.*, “HRS/EHRA/ECAS expert consensus statement on catheter and surgical ablation of atrial fibrillation: Recommendations for personnel, policy, procedures and follow-up. A report of the Heart Rhythm Society (HRS) Task Force on Catheter and Surgical Ablation of,” *Europace: Eur. Pacing, Arrhythmias, Cardiac Electrophysiol.: J. Working Groups on Cardiac Pacing, Arrhythmias, Cardiac Cellular Electrophysiol. Eur. Soc. Cardiol.*, vol. 9, no. 6, pp. 335–379, 2007, doi:10.1093/europace/eum120.
- [14] T. Neumann *et al.*, “Circumferential pulmonary vein isolation with the cryoballoon technique results from a prospective 3-center study,” *J. Amer. College Cardiol.*, vol. 52, no. 4, pp. 273–278, 2008, doi:10.1016/j.jacc.2008.04.021.
- [15] K. P. Phillips *et al.*, “Anatomic location of pulmonary vein electrical disconnection with balloon-based catheter ablation,” *J. Cardiovasc. Electrophysiol.*, vol. 19, no. 1, pp. 14–18, 2008, doi:10.1111/j.1540-8167.2007.00964.x.
- [16] W. Moreira *et al.*, “Long-term follow-up after cryothermic ostial pulmonary vein isolation in paroxysmal atrial fibrillation,” *J. Amer. College Cardiol.*, vol. 51, no. 8, pp. 850–855, 2008, doi:10.1016/j.jacc.2007.08.065.
- [17] Y.-Y. Hsu *et al.*, “A novel strain relief design for multilayer thin film stretchable interconnects,” *IEEE Trans. Electron Devices*, vol. 60, no. 7, pp. 2338–2345, Jul. 2013.
- [18] D. H. Kim *et al.*, “Electronic sensor and actuator webs for large-area complex geometry cardiac mapping and therapy,” *Proc. Nat. Acad. Sci. USA*, vol. 109, pp. 19 910–19 915, 2012.
- [19] J. Jalife, “Mother rotors and fibrillatory conduction: A mechanism of atrial fibrillation,” *Cardiovasc. Res.*, vol. 54, no. 2, pp. 204–216, 2002, doi:10.1016/S0008-6363(02)00223-7.
- [20] D. Katritsis, E. Giazitzoglou, D. Sougiannis, E. Vouridis, and S. S. Po, “Complex fractionated atrial electrograms at anatomic sites of ganglionated plexi in atrial fibrillation,” *Europace: Eur. Pacing, Arrhythmias, Cardiac Electrophysiol.: J. Working Groups Cardiac Pacing, Arrhythmias, Cardiac Cellular Electrophysiol. Eur. Soc. Cardiol.*, vol. 11, no. 3, pp. 308–315, 2009, doi:10.1093/europace/eup036.
- [21] S. M. Narayan *et al.*, “Treatment of atrial fibrillation by the ablation of localized sources,” *J. Amer. College Cardiol.*, vol. 60, no. 7, pp. 628–636, 2012, doi:10.1016/j.jacc.2012.05.022.
- [22] S. M. Narayan, J. Patel, S. Mulpuru, and D. E. Kravmen, “Focal impulse and rotor modulation ablation of sustaining rotors abruptly terminates persistent atrial fibrillation to sinus rhythm with elimination on follow-up: A video case study,” *Heart Rhythm: Official J. Heart Rhythm Soc.*, vol. 9, no. 9, pp. 1436–1439, 2012, doi:10.1016/j.hrthm.2012.03.055.
- [23] D. H. Kim *et al.*, “Optimized structural designs for stretchable silicon integrated circuits,” *Small*, vol. 5, no. 24, pp. 2841–2847, 2009.
- [24] D. H. Kim *et al.*, “Thin, flexible sensors and actuators integrated in surgical sutures for targeted wound monitoring and therapy,” *Small*, 2012, doi:10.1002/sml.201200933.

ABOUT THE AUTHORS

Stephen P. Lee, photograph and biography not available at the time of publication.

Lauren Klinker, photograph and biography not available at the time of publication.

Leon Ptaszek, photograph and biography not available at the time of publication.

John Work, photograph and biography not available at the time of publication.

Cliff Liu, photograph and biography not available at the time of publication.

Fernando Quivara, photograph and biography not available at the time of publication.

Chad Webb, photograph and biography not available at the time of publication.

Canan Dagdeviren, photograph and biography not available at the time of publication.

John A. Wright, photograph and biography not available at the time of publication.

Jeremy N. Ruskin, photograph and biography not available at the time of publication.

Marvin Slepian, photograph and biography not available at the time of publication.

Yonggang Huang, photograph and biography not available at the time of publication.

Moussa Mansour, photograph and biography not available at the time of publication.

John A. Rogers, photograph and biography not available at the time of publication.

Roozbeh Ghaffari, photograph and biography not available at the time of publication.